

TOP VIEW

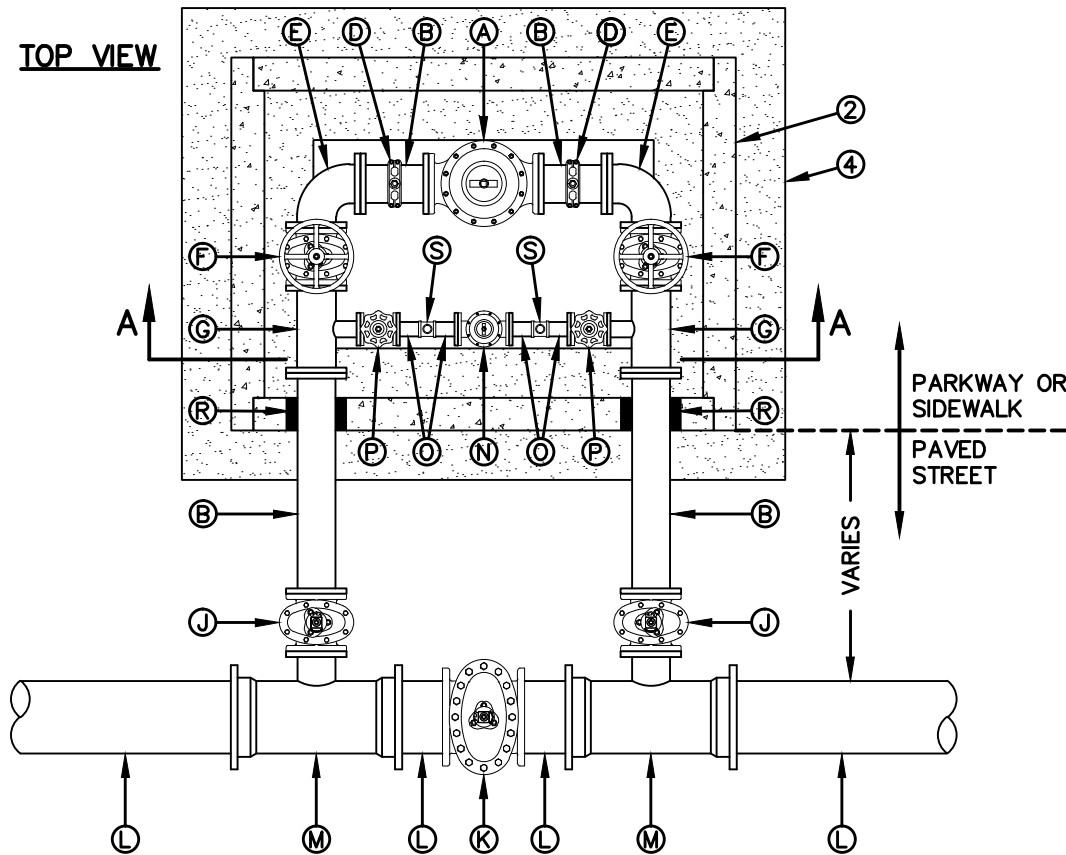

SECTION A-A

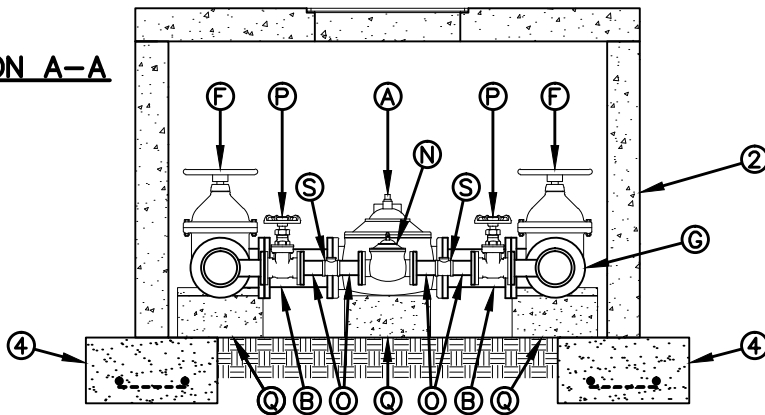

GENERAL NOTES:

1. INSTALLATION SHALL GENERALLY BE FOR A MAIN-LINE 12" AND SMALLER. INSTALLATION OF OTHER SIZED VALVES IS SIMILAR.
2. VALVE VAULT SHALL BE TYPE "E", SEE DETAIL 295-1. FOR PRESSURE REDUCING VALVES LARGER THAN 6", VAULT SIZE SHALL BE INCREASED TO ACCOMMODATE LARGER APPURTENANCES. LARGER VAULT DIMENSIONS MUST BE APPROVED BY THE EPWU.
3. PRESSURE RELIEF VALVE MAY BE LOCATED EITHER UPSTREAM OR DOWNSTREAM OF PRESSURE REDUCING VALVE DEPENDING ON A SUITABLE DISCHARGE LOCATION. WHEN RELIEF VALVE IS LOCATED DOWNSTREAM REDUCING VALVE SHALL BE EQUIPPED WITH A PRESSURE RELIEF PILOT AS NOTED IN A AND N. RELIEF VALVE SIZE IS GENERALLY ONE OR TWO SIZES SMALLER THAN THE SIZE OF THE MAINLINE. SEE EPWU STANDARD DETAILS 265-1 THROUGH 265-8 FOR INSTALLATION.
4. 12"x24" FOOTING WITH No.5 REBAR AT 12" ON CENTER EACH WAY IS REQUIRED.
5. TEST OUTLETS TO BE PLACED BEFORE AND AFTER PRESSURE REDUCERS. SEE DETAIL 264-5 FOR TEST OUTLET DETAIL.

CONSTRUCTION KEY NOTES:

- A. 6" FLANGED PRESSURE REDUCING VALVE, WITH SURGE RELIEF PILOT, FOR HIGH FLOWS.
- B. 6" FLANGED DUCTILE IRON SPOOL.
- D. 6"x $\frac{3}{4}$ " TAPPING SADDLE & $\frac{3}{4}$ " TEST OUTLET WITH CORPORATION STOP.
- E. 6" FLANGED 90° BEND.
- F. 6" FLANGED GATE VALVE WITH HANDWHEEL.
- G. 6"x2" FLANGED TEE.
- J. 6" FLANGED GATE VALVE WITH VALVE BONNET BOX AND COVER.
- K. GATE VALVE (CLOSED) SIZE AS SPECIFIED, WITH VALVE BONNET BOX AND COVER.
- L. MAINLINE, SIZE AS SPECIFIED.
- M. MECHANICAL JOINT TEE WITH A 6" FLANGED BRANCH, MAINLINE SIZE AS SPECIFIED.
- N. 2" FLANGED PRESSURE REDUCING VALVE, WITH SURGE RELIEF PILOT, FOR LOW FLOWS.
- O. 2" FLANGED BRASS OR DUCTILE IRON SPOOL.
- P. 2" FLANGED GATE VALVE WITH HANDWHEEL.
- Q. VALVES INSTALLED ON NATURAL GROUND WITH CONCRETE SUPPORTS AS REQUIRED.
- R. WALL SLEEVES AND/OR GROUT.
- S. 2"x1" BRONZE TEE WITH 1" TO $\frac{3}{4}$ " ADAPTER & $\frac{3}{4}$ " TEST OUTLET WITH CORPORATION STOP.

STANDARD
DETAIL

DATE: 7/1994
REV: 7/20/2009

PRESSURE REDUCING 6" VALVE (BY-PASSED)
BEHIND CURB INSTALLATION

N.T.S.



DETAIL No.
264-1